

CMOS Transimpedance Amplifier suitable for 2.5Gbps APD and PIN Applications

Main Features

- APD: Typical **-34 dBm** sensitivity at 2.5 Gbps when used with typical APD ($C_{PD} = 0.42 \text{ pF}$, $BER = 10^{-10}$)
- PIN: Typical **-28 dBm** sensitivity, 0 dBm overload at 2.5 Gbps when used with 0.9 A/W PIN ($C_{PD} = 0.42 \text{ pF}$, $BER = 10^{-10}$)
- Typical transimpedance: 12 k Ω
- No internal ROSA/BOSA VDD supply decoupling capacitor required for typical operation
- Single +3.3 V supply voltage and typical 21.5 mA supply current
- Internal regulated photodiode bias
- Photodiode Receiver Signal Strength Indication (RSSI) monitor output, with selectable Sink or Source current modes
- Selectable anode or cathode photodiode current monitoring function

Product Overview

The HiLight HLR2G50 is a high sensitivity transimpedance amplifier (TIA) with automatic gain control (AGC) manufactured in a pure CMOS process. The AGC enables over 29 dB of dynamic operating range, resulting in a high performance TIA suitable for fiber optic applications such as GPON and OC-48 SONET.

The HLR2G50 is pad compatible with all popular 2.5Gbps TIAs whilst offering superior performance and additional features. The HLR2G50 can be used in new applications or as a drop-in replacement for existing TIAs without major re-design effort.

Featuring photodiode monitor and monitor invert functions the HLR2G50 offers the most flexible, high performance receiver solution for 2.5 Gbps applications available.

Applications

- GPON, OC-48, 2xFC
- APD Long reach receivers
- SFF, SFP Transceivers

Block Diagram

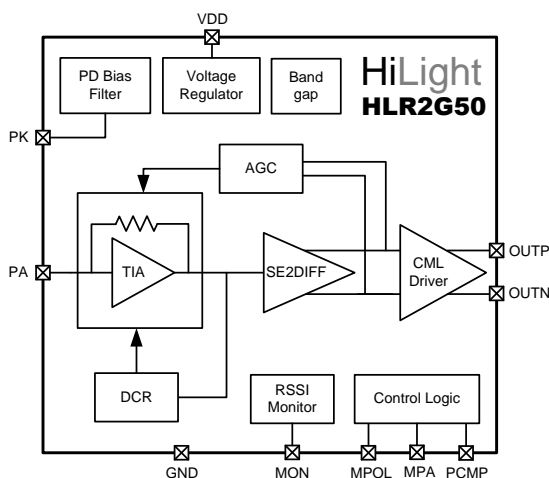

Figure 1 - HLR2G50 Block diagram

Pad Out

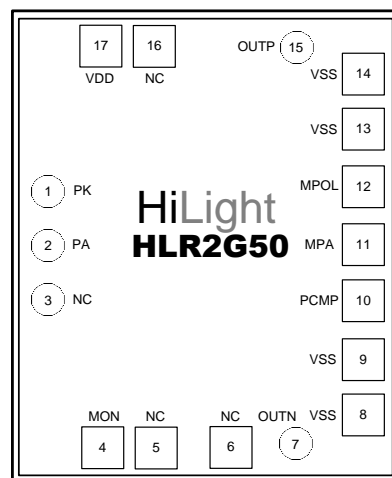

Figure 2 – HLR2G50 Pad Out

Ordering Information

Part Number	Package
HLR2G50-WP	400 known good die in waffle tray packs
HLR2G50-GRP4-5K	5,000 pcs known good die reconstructed into a 4 inch format on a 6" Grip Ring.
HLR2G50-GRP6-5K	5,000 pcs known good die reconstructed into a 4 inch format on a 8" Grip Ring
HLR2G50-GRP6-10K	10,000 pcs known good die reconstructed into a 6inch format on a 8" Grip Ring

HiLight Address and Contact Details

HiLight Semiconductor Ltd
Delta House
Enterprise Road
Southampton
SO16 7NS
United Kingdom
Tel: +44 238 097 0330

Please contact your local sales representative or sales@hilight-semi.com for further information and support.